



BXUV.D703

Design/System/Construction/Assembly Usage Disclaimer

- Authorities Having Jurisdiction should be consulted in all cases as to the particular requirements covering the installation and use of UL Certified products, equipment, system, devices, and materials.
- Authorities Having Jurisdiction should be consulted before construction.
- Fire resistance assemblies and products are developed by the design submitter and have been investigated by UL for compliance with applicable requirements. The published information cannot always address every construction nuance encountered in the field.
- When field issues arise, it is recommended the first contact for assistance be the technical service staff provided by the product manufacturer noted for the design. Users of fire resistance assemblies are advised to consult the general Guide Information for each product category and each group of assemblies. The Guide Information includes specifics concerning alternate materials and alternate methods of construction.
- Only products which bear UL's Mark are considered Certified.

BXUV - Fire Resistance Ratings - ANSI/UL 263 Certified for United States

BXUV7 - Fire Resistance Ratings - CAN/ULC-S101 Certified for Canada

[See General Information for Fire-resistance Ratings - ANSI/UL 263 Certified for United States Design Criteria and Allowable Variances](#)

[See General Information for Fire Resistance Ratings - CAN/ULC-S101 Certified for Canada Design Criteria and Allowable Variances](#)

Design No. D703

Restrained Assembly Ratings — 1, 1-1/2, 2 or 3 Hr.

(See Items 7A and 9)

Unrestrained Assembly Ratings — 1 or 1-1/2 Hr. (See Item 7A)

Unrestrained Beam Rating — 1-1/2 Hr.

This design was evaluated using a load design method other than the Limit States Design Method (e.g., Working Stress Design Method). For jurisdictions employing the Limit States Design Method, such as Canada, a load restriction factor shall be used — See Guide [BXUV](#) or [BXUV7](#)

*** Indicates such products shall bear the UL or cUL Certification Mark for jurisdictions employing the UL or cUL Certification (such as Canada), respectively.**

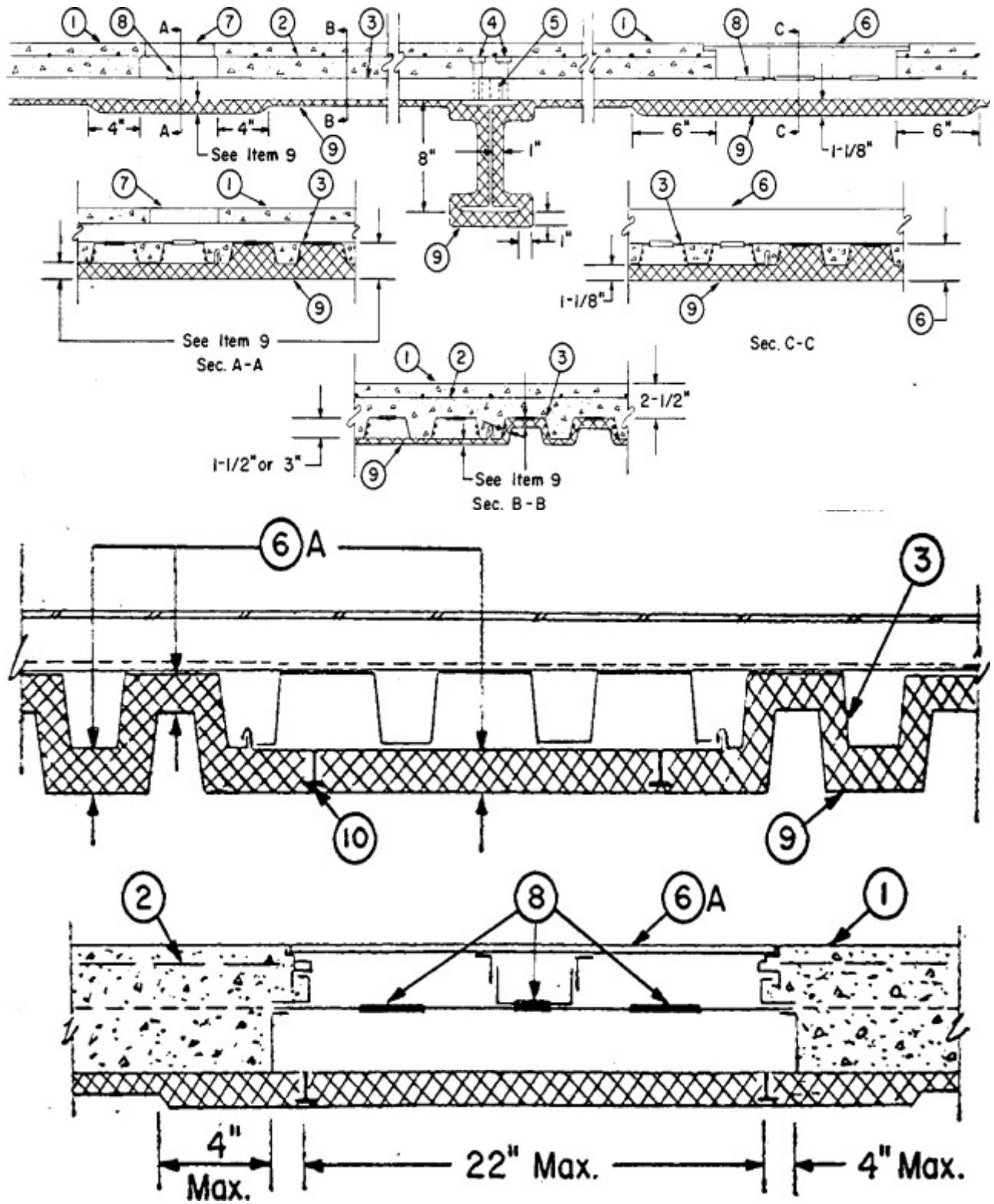

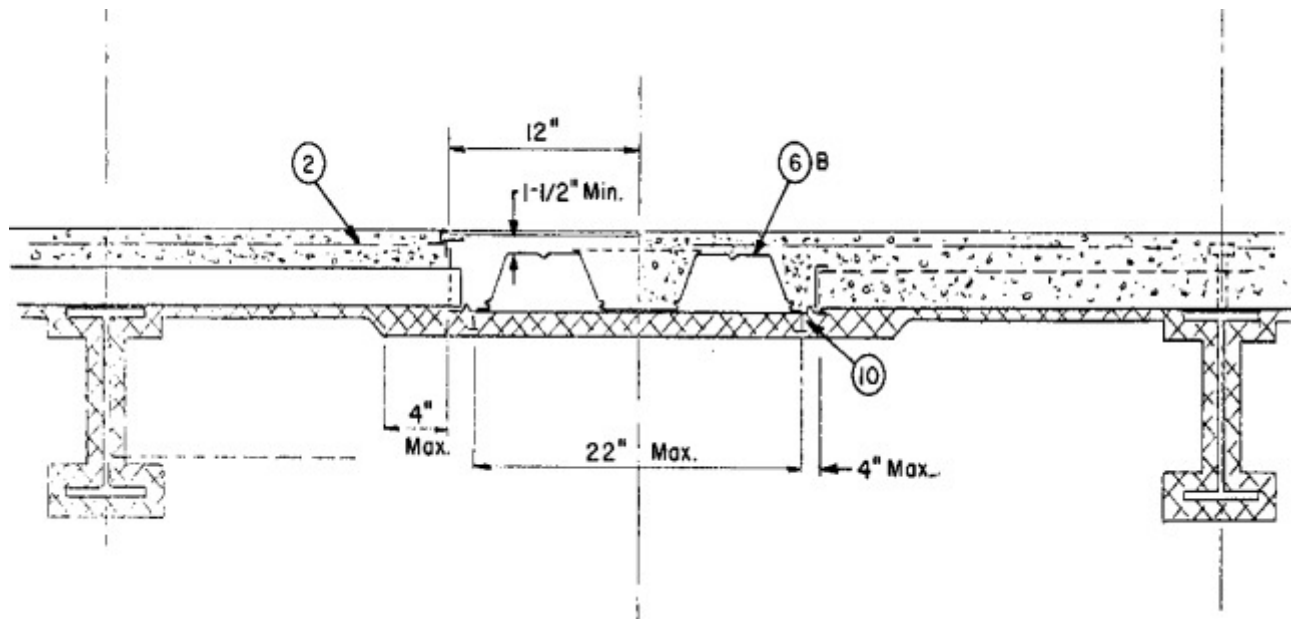
**Beam**

— W8x20, min size.

1. **Lightweight Concrete** — Expanded shale, clay or slate aggregate by rotary-kiln method, 105 pcf unit weight, 3500 psi compressive strength, vibrated. **Normal Weight Concrete** — Siliceous or carbonate aggregate, 145 pcf (+ or -) 3 pcf unit weight, 3500 psi compressive strength, vibrated.
2. **Welded Wire Fabric** — 6x6 — W2.9xW2.9.
3. **Steel Floor and Form Units*** — Composite or non-composite, 1-1/2, 2 or 3 in. deep galv units. Min gauges are No. 22 MSG for fluted and 20/20 MSG for cellular. For spans with trench headers the allowable loading shall be based on noncomposite design. The following combinations of units may be used:
 - (1) All fluted.
 - (2) One or more fluted to one cellular.

ASC STEEL DECK, DIV OF ASC PROFILES L L C — 36 in. wide 2WH-36, 2WHS-36, 2WHF-36, 2WHF-36A, 3WxH-36, 3WxHF-36, 3WxHF-36A, 3WH-36, 3WHF-36, 3WHF-36A, 3W-36, 3WF-36, DG3W-36, DG3WF-36. All units may be galvanized or Prime Shield. Non-cellular decks may be vented designated with a "V" suffix to the product name.

CANAM GROUP INC — 36 in. wide Type P-3623, P-3606, P-3615 and 24 in wide Type P-2432 composite, 36 in. wide Type P-3606 and P-3615 non-composite; 24 or 36 in. wide Type LF3. Type LF3 unit may be phos/ptd.; 36 in. wide Types 1.5B, 1.5BI, 1.5BL and 1.5BL.

CANAM STEEL CORP — 36 in. wide Type P-3623, P-3606, P-3615 and 24 in wide Type P-2432 composite, 36 in. wide Type P-3606 and P-3615 non-composite.

KAM INDUSTRIES LTD, DBA CORDECK — QL Types, 24 in. wide, 2 in. QL-99, AKX, TKX, AKD; 36 in. wide, 2 or 3 in. 99, AKX, WKX, AKD, WKD; 24 in. wide QL-3, QL-UKX; 24 or 30 in. wide, 3 in. QL-GKX, -GKXH, -GKX-A.

CHIA TEH CONSTRUCTION MATERIAL CO LTD — 24 or 36 in. wide Mac-Lok 3; 24 in. wide CFD-3.

CANAM STEEL CORP — 24, 30 or 36 in. wide, Types 1-1/2 in. BL and BLC; 24 or 36 in. wide, Types LF2, LF3, LF15 and LFC1, LFC2, LFC3; 24 in. wide, Types NL, NLC. Types BL, LF2, LF3, NL. Units may be phos/ptd.

DECK WEST INC — 36 in. wide Type 2-DW, 3-DW, B-DW or BA-DW.

DESIGN ASSISTANCE CONSTRUCTION SYSTEMS INC — 36 in. wide Type DACS1.5CD, or 24 in. wide Type DACS2.0CD, or DACS3.0CD.

EPIC METALS CORP — 24 in. wide, Types EC150, -300, -366, ECP150, -300, -366; 24 or 30 in. wide, Types EPC2+, EPC3+; 36 in. wide, Types EC266, ECP266.

+Min. 20/18 gauge.

KAM INDUSTRIES LTD, DBA CORDECK — Hi-Bond Types 24 in. wide 3KA1F24; 30 in. wide 3KF30, 3P30.

MARLYN STEEL DECKS INC — Type 1.5 CF, 2.0 CF or 3.0 CF.

NEW MILLENNIUM BUILDING SYSTEMS L L C — 24, 30 or 36 in. wide Types 1.5CD, 1.5CDI, 1.5CFD; 24 or 36 in. wide, Types 2.0CD, 3.0CD, 2.0CFD, 3.0CFD, 3.0CFDES. Fluted units may be phos/painted or galvanized.

STEEL MASTERS INTERNATIONAL DEPENDABLE STEEL — 36 in. wide Types 2WH-36, 3WH-36. Units may be phos/painted or galvanized.

VERCO DECKING INC - A NUCOR CO — FORMLOK™ deck types PLB, B, BR, PLN3, N3, PLN, N, PLW2, W2, PLW3, W3. Units are min 24 in. wide and may be galvanized or phos./ptd. Units may be cellular with the suffix "CD" added to the product name, respectively. Deck may be vented or non-vented.

VULCRAFT, DIV OF NUCOR CORP — 24, 30 or 36 in. wide Types 1.5VL, 1.5VLI, 1.5PLVLI, 1.5VLP, 1.5PLVLP; 24 or 36 in. wide Types 2VLI, 2.0PLVLI, 3VLI, 3.0PLVLI, 2VLP, 2.0PLVLP, 3VLP, 3.0PLVLP. Types 1.5VLI, 1.5PLVPI, 2VLI, 2.0PLVL1, 3VLI, 3.0PLVLI units may be phos/ptd. 36 in. wide Type 1.5 SB; 24 or 36 in wide Types 2.0 SB, 3.0 SB, 36 in. wide Type High Strength 1.5 SBI, 36 in. wide Type High Strength 1.5 SBN. Units may be phos/ ptd.

Spacing of welds attaching units to supports shall be 12 in. OC max. Unless noted otherwise, adjacent units button-punched or welded together 36 in. OC max along side joints.

Alternate Construction — Noncomposite units of the same type listed above may be used provided allowable loading is calculated on the basis of noncomposite design.

4. **Shear Connectors** — Studs, 3/4 in. diam by 3 to 4-1/2 in. long, headed type or equivalent per AISC specification. Welded to the top flange of the beam through the deck.

5. **Joint Cover** — 2 in. wide pressure sensitive cloth tape.

6. **Trench Header** — (Bearing the UL Listing Mark). Constructed of steel with metal edge screeds. When the trench header is located near the supports the load carrying capacity of the span may be based on the allowable moment or shear stress of the form units at the edge of the trench away from the support, or on the allowable composite moment or shear capacity of the slab at the center of the span whichever governs. The spray-applied resistive materials thickness on floor units below this trench header shall be 1-1/8 in. below the bottom plane of units, with the flutes completely filled, except for 2 in. and 3 in. deep floor units, where thickness in flutes shall be 1-1/8 in.

6A. **Trench Header** — Trench header (bearing the UL Listing Mark), without the bottom pan. The allowable superimposed load for spans with bottomless trench shall be based on noncomposite design. This trench header, with width ranging from min 12 in. to max 36 in., consists of two cell closers which conform to the contour of the floor units, placed along the sides of the desired trench location and welded to the floor units. The side rails, consisting of extruded aluminum screeds secured to galv steel channels (min 18 MSG) are positioned over the cell closers, aligned and welded or riveted to the closers and floor units. A separate U shaped channel (min 18 ga) serving as the power compartment, is welded or riveted to the floor units. Steel cover plates, 1/4 in. thick, shall be secured to the side rails. In bottomless trench headers wider than 18 in., each side joint of the steel floor units shall be welded with a 1 in. long weld near the trench header centerline. For QL-GKX-24 or -30 cellular floor units only, a separate KED-PTS (UL Listed)

power transition sleeve is secured to power compartment with one rivet or screw. The use of this trench requires additional protection underneath the trench.

For 3 Hr Restrained Assembly Rating the required fireproofing thicknesses are 2-1/4 in. in the crests and 2-1/8 in. on valleys and flat plates. For 2 Hr Restrained Assembly Rating fireproofing thicknesses may be reduced to 1-3/4 in. in crests and 1-5/8 in. on valleys and flat plates. These thicknesses shall extend a min of 4 in. beyond the edge of the trench header.

6B. Feeder Duct System — (As an alternate to Items 6 or 6A) Consists of 3 in. deep, nom 24 in. wide, 20/18 MSG Type QL-WKM or QL-WKM-E cellular steel floor unit (feeder duct) and nom 24 by 24 in. junction boxes. The valley between the two cells of the feeder duct may or may not be covered by a steel plate to form a third cell. Feeder duct installed at the same elevation and perpendicular to 2 or 3 in. deep fluted and/or cellular steel floor units which are cantilevered from support beams on one or both sides of the feeder duct. The junction boxes consisting of extruded aluminum screeds, 18 galv steel outside flute closures, 16 galv steel compartment divider, and 0.21 in. thick steel cover plate are used at intersections of 2 or 3 in. cellular units and the feeder duct, where desired. Bottom tabs of the flute closures are fastened to the valleys of the 2 or 3 in. units and to the feeder duct with self-drilling tek fasteners, while the cover plate is retained in position by four latch clips, one near each corner of the plate. The height and the level of the aluminum screed are adjusted by four adjustment screws, two each on opposite sides.

In between the junction boxes the ends of the 2 or 3 in. fluted and/or cellular units are covered with steel end closure angles tack-welded to the top of the units. Welded wire fabric (Item 2) extends over the feeder duct between junction boxes. The allowable superimposed load for spans with the feeder duct system shall be based on noncomposite design. Steel studs with discs (Item 10) shall be welded to the underside of the feeder duct in two rows. The spacing between rows shall not exceed 22 in. OC and the spacing of studs in each row shall not exceed 24 in. OC. The use of this feeder duct system requires additional protection underneath the feeder duct. For **3 Hr. Restrained Assembly Rating** the required fireproofing thicknesses are 2-3/4 in. the crests and 2-1/2 in. on valleys and flat plates. For **2 Hr. Restrained Assembly Rating**, fireproofing thicknesses may be reduced to 2 in. in crests and 1-3/4 in. on valleys and flat plates. These thicknesses shall extend a min of 4 in. beyond the edges of the feeder duct.

KAM INDUSTRIES LTD, DBA CORDECK — 24 in. wide Types QL-QKM or QL-WKM-E.

6C. Trench Header — With an intermittent bottom (as an alternate to Item 6 or 6A for 2 h or less ratings only) — (Bearing the UL Listing Mark) — The allowable superimposed load for spans with an intermittent bottom trench header shall be based on noncomposite design. The intermittent bottom trench header, with a maximum width of 24 in., consists of a horizontal closure plate (min. No. 22 MSG), over the fluted deck sections at the desired trench header location and affixed to the floor units by welding or screws (No. 14 by 3/4 in. long self-tapping, self-drilling). At the trench header where horizontal plates cover the fluted units, concrete is to be vibrated into the voids formed by the plate and fluted units. The side rails consist of extruding aluminum screeds secured to the galv steel channels (min. No. 18 MSG), positioned over the edge of the horizontal closure plates, aligned and welded to the cells and fluted floor units. A separate U-shaped galv steel channel (min. No. 18 MSG), serving as the power compartment is welded to the horizontal closure plates and floor units. Steel cover plates 1/4 in. thick, shall be screw attached to the side rails. For **2 h or less Restrained Assembly Rating**, the required fireproofing thickness shall be 1-1/8 in. applied in conjunction with stud pins with discs below the trench header (see Item 10).

7. Header Duct — (Bearing the UL Listing Mark) 1-1/2 in. deep by 6-1/3 in. wide. Housing constructed of steel.

7A. Electrical Inserts — (Not shown) — Preset and after set electrical inserts Classified as **Outlet Boxes and Fittings Classified for Fire Resistance** *. Unless specified otherwise for a particular preset electrical insert type, the spacing of the preset electrical inserts shall be not less than 24 in. on center along cellular steel floor units with not more than one preset electrical insert in each 8 sq ft of floor area. The required thickness of Spray-Applied Fire Resistive Materials on the steel floor units with inserts shall be sprayed the entire length and width of the units between supports and shall extend beyond the edge of inserts onto adjacent floor units for a minimum horizontal width of 12 in.

(1)**KAM INDUSTRIES LTD, DBA CORDECK** Inserts.

(Tapmate II, -II-EA, -II-FN, -II-EAFN; Series KEB)

Installed per accompanying installation instructions over factory-punched holes in QL-AXX or QL-WKX floor units. Inserts are used in the pre-active, active or abandoned condition.

Restrained Assembly Rating, Hr	Floor Unit Type	Concrete Type	Min Spray Applied Fire Resistive Mtl Thk In.
(Tapmate II)			

(Tapmate II or II-EA Insert)			
2	QL-AKX, -WKX	NW	7/8
2	QL-AKX	LW	11/16
2	QL-WKX	LW	15/16
3	QL-AKX	NW	1-1/4
3	QL-AKX	LW	1-1/2
3	QL-WKX	NW	1-13/16
3	QL-WKX	LW	1-3/8
(Tapmate II-FN or II-EAFN)			
2	QL-AKX, QL-WKX	NW	1/2
3	QL-AKX, QL-WKX	NW	3/4
2	QL-AKX, QL-WKX	LW	3/4

The hole cut in insert cover for passage of wires shall be no more than 1/8 in. larger diam than the wire. For abandonment of Tapmate inserts, see installation instructions.

The Tapmate II-FN insert may use KEB-HP-1 outlet box fittings in lieu of the KEB-PC flush cover fittings.

(Tapmate II-EAF-FC1; Series KEB)

Installed per accompanying installation instructions over factory-punched holes in QL-WKX floor units. Inserts are used in the pre-active, active, or abandoned condition. Required Spray-Applied Fire Resistive Materials thicknesses on floor units with inserts are:

Restrained Assembly Rating, Hr	Floor Unit Type	Concrete Type	Min Spray Applied Fire Resistive Mtl Thk In.
2	QL-WKX	NW	1/2

For abandonment see installation instructions.

(Tapmate III-FN, III-EAFN, III-EAFN-FC1; Series KEC)

Installed per accompanying installation instructions over factory-punched holes in QL-AKD or QL-WKD floor units. Inserts are used in the pre-active, active, or abandoned condition. Required spray-applied resistive materials thickness on floor units with inserts are:

Restrained Assembly Rating, Hr	Floor Unit Type	Concrete Type	Min Spray Applied Fire Resistive Mtl Thk In.
(Tapmate III-FN or III-EAFN)			
2	QL-AKD, WKD	NW	1/2
3	QL-AKD, WKD	NW	3/4
2	QL-AKD, WKD	LW	13/16
(Tapmate III-EAFN-FC1)			
2	QL-WKD	NW	1/2

The hole cut in insert cover for passage of wires shall be no more than 1/8 in. larger diam than the wire. For abandonment of Tapmate inserts, see installation instructions.

The Tapmate III insert may use KEB-HP-1; Series KEC outlet box fittings with the same hourly rating and fireproofing thicknesses as specified for the Tapmate III-EAFN electrical inserts.

(Tapmate IV, IV-EA, IV-H, IV-H-M, IV-S)

Installed per accompanying installation instructions over factory-punched holes in QL-GKX-24 or -30 floor units. Inserts are used in the preactive, active or abandoned condition. Required spray-applied resistive materials thicknesses on floor units with inserts are:

Restrained Assembly Rating, Hr	Floor Unit Type	Concrete Type	Min Spray Applied Fire Resistive Mtl Thk In.
(Tapmate IV, IV-H, IV-H-M, IV-S; Series KED)			
1	QL-GKX	NW, LW	3/8
1-1/2	QL-GKX	NW	1/2
1-1/2	QL-GKX	LW	9/16
2	QL-GKX	NW	5/8
2	QL-GKX	LW	3/4
3	QL-GKX	NW	1-1/4
3	QL-GKX	LW	1-1/2
(Tapmate IV-EA)			
1	QL-GKX	NW, LW	1/2
1-1/2	QL-GKX	NW	9/16
1-1/2	QL-GKX	LW	5/8
2	QL-GKX	NW	3/4
2	QL-GKX	LW	7/8

The holes cut in insert cover for passage of wires shall be no more than 1/8 in. larger diameter than the wire. For abandonment of inserts see installation instructions.

Type KED-HP-1 outlet box fittings may be used with Tapmate IV box assemblies or in lieu of Tapmate IV or IV-EA fittings with the same hourly ratings and protection material thicknesses as specified for the above electrical inserts.

(Tapmate IV-FN-S, IV-FN-H, IV-EAFN)

Installed per accompanying installation instructions over factory-punched holes in QL-GKX-24 or -30 floor units. Inserts are used in the preactive, active or abandoned condition.

Required Spray-Applied Fire Resistive Materials thicknesses on floor units with inserts are:

Restrained Assembly Rating, Hr	Floor Unit Type	Concrete Type	Min Spray Applied Fire Resistive Mtl Thk In.
(Tapmate IV-FN-S, IV-FN-H, IV-EAFN)			
1	QL-GKX	LW, NW	3/8
2	QL-GKX	NW	1/2

2	QL-GKX	LW	13/16
3	QL-GKX	NW	3/4

The required thickness below inserts shall be sprayed the entire width and length of floor units between supports and extend beyond the edge of inserts onto adjacent units for a horizontal width of 12 in. The hole cut in insert cover for passage of wires shall be no more than 1/8 in. larger diameter than the wire. For abandonment see installation instructions.

Type KED-HP-1 outlet box fittings may be used with Tapmate IV box assemblies or in lieu of Tapmate IV-FN-S, IV-FN-H, IV-EAFN fittings with the same hourly ratings, insert spacing and protection material thicknesses as specified for the above electrical inserts.

KAM INDUSTRIES LTD, DBA CORDECK – Tapmate II, II-EA, II-FN, II-EAFN, II-EAFN-FC1; Series KEB. Tapmate III-FN, III-EAFN, III-EAFN-FC1; Series KEC. Tapmate IV, IV-EA, IV-EAFN, IV-FN-S, IV-FN-H, IV-H, IV-H-M, IV-S; Series KED, Tapmate V.

The hole cut in insert cover for passage of wires shall be no more than 1/8 in. larger diameter than the wire. For abandonment see installation instructions.

Type KED-HP-1 outlet box fittings may be used with Tapmate IV box assemblies or in lieu of Tapmate IV-FN-S, IV-FN-H, IV-EAFN fittings with the same hourly ratings and protection material thicknesses as specified for the above electrical inserts.

(Tapmate KED-MSA Multi-Service After set Inserts)

Installed per accompanying installation instructions in core-drilled holes over QL-GKX-24 or -30 steel floor units. Spacing of after set inserts shall be not more than one insert per each 7-1/2 sq ft. of floor area with not less than 25-1/2 in. between edges of adjacent after set inserts. After set inserts may be installed with either the flip lid plastic cover (KEC-PC3, PC4 and PC5 components) or the Deluxe Cover (KED-NAC type).

Required Spray-Applied Fire Resistive Materials thicknesses on steel floor units with inserts are tabulated below:

Restrained Assembly Rating Hr	Floor Unit Type	Concrete Type	Min Spray Applied Fire Resistive Mtl Thkns In.
1	QL-GKX	NW, LW	3/8
1-1/2	QL-GKX	NW	1/2
1-1/2	QL-GKX	LW	9/16
2	QL-GKX	NW	5/8
2	QL-GKX	LW	3/4
3	QL-GKX	NW	1-1/4
3	QL-GKX	LW	1-1/2

(Tapmate VI)

Installed per accompanying installation instructions over factory-punched holes in 3 in. deep Type QL-GKX, 24 in. wide cellular steel floor units. Refer to installation instructions for Classified assemblies. The required Spray-Applied Fire Resistive Materials thicknesses on steel floor units with inserts are:

Restrained Assembly Rating, Hr	Floor Unit Type	Concrete Type	Min Spray Applied Fire Resistive Mtl Thk In.
1, 1-1/2	QL-GKX	LW, NW	3/8
2	QL-GKX	LW, NW	1/2
3	QL-GKX	LW, NW	13/16

KAM INDUSTRIES LTD, DBA CORDECK — Tapmate II, II-EA, II-FN, II-EAFN, II-EAFN-FC1; Series KEB. Tapmate III-FN, III-EAFN, III-EAFN-FC1; Series KEC. Tapmate IV, IV-EA, IV-EAFN, IV-FN-S, IV-FN-H, IV-H, IV-H-M, IV-S; Series KED, Tapmate KED-MSA, Tapmate VI.

(2) **Wiremold Co. and Kam Industries LTD d/b/a Cordeck** Preset Inserts.

The NRG Bloc IV insert is furnished by **KAM INDUSTRIES LTD d/b/a CORDECK**. The service fitting components are furnished by **Wiremold Co.** Installed per accompanying installation instructions over factory-punched holes in 3 in. deep K-Type cellular steel floor units (furnished by KAM INDUSTRIES LTD d/b/a CORDECK). Either Type RAKM-II, FAKM-II, S36BB, S36CC, S36PB, S36PP, S38CC, S38BB, S38PB, S38PP, FPCTC, FPBTC, FPFPTC service fittings or Type S3AXBP abandonment plate are installed with Type N-R-G Bloc IV Series preset inserts per accompanying installation instructions. Refer to installation instructions for Classified assemblies. The required Spray-Applied Fire Resistive Materials thicknesses on steel floor units with inserts are:

Restrained Assembly Rating, Hr	Floor Unit Type	Concrete Type	Min Spray Applied Fire Resistive Mtl Thk In.
(RAKM-II, S36BB, S36CC, S36PB, S36PP, S38CC, S38BB, S38PB, S38PP, FPCTC, FPBTC, FPFPTC, S3AXBP)			
1, 1-1/2	3 in. K	LW, NW	3/8
2	3 in. K	LW, NW	1/2
3	3 in. K	LW, NW	13/16
(FAKM-II)			
1	3 in. K	LW, NW	3/8
1-1/2	3 in. K	LW, NW	7/16
2	3 in. K	LW, NW	9/16
3	3 in. K	LW, NW	3/4

WIREMOLD CO — Type N-R-G Bloc IV Series inserts; Type RAKM-II, FAKM-II, S36BB, S36CC, S36PB, S36PP, S38CC, S38BB, S38PB, S38PP, FPCTC, FPBTC, FPFPTC service fittings or Type S3AXBP abandonment plate.

6. **Access Openings** — As required, with grommets.

7. **Spray-Applied Resistive Materials*** — Applied by mixing with water and spraying in more than one coat to a final thickness as shown above and in the following table, to steel surfaces which must be clean and free of dirt, loose scale and oil. Min avg and min ind density of 15/14 pcf respectively. Min avg and min ind density of 19/18 pcf respectively for Types 7GP and 7HD. For method of density determination, refer to Design Information Section. Types 4, 5GP, 7GP, 7HD, 8GP, 9GP, VP4 may be used only in general floor areas without concrete penetrations with all fluted steel floor units or blends consisting of one or more fluted units to one 24 in. wide max cellular unit, 1-1/2 or 3 in. deep, with cells spaced approx 6 and 8 in. respectively. Use of a spatter coat, Type DK, DK2, DK3, SK-1 or SK-III, is required on all cellular units with flat plate on the bottom, optional on other steel surfaces. Thickness of the spatter coat is included in the total final thickness of the protection material.

Rating Hr	Spray Applied Fire Resistive Mtl			Header Duct		
	General Floor Area			Crests	Valley	Flat Plate
	Crests	Valley	Flat Plate			
1 and 1-1/2	3/8 in.	3/8 in.	3/8 in.	—	—	—
2	5/8 in.	3/8 in.	3/8 in.	2-1/2 in.	1 in.	1 in.
3	1 in.	3/4 in.	3/4 in.	2-5/8 in.	1-1/8 in.	1-1/8

GCP KOREA INC — Types MK-6/CBF, MK-6/ED, MK-6/HY, MK-6s, SK-III, Monokote Acoustic 1.

PYROK INC — Type LD.

SOUTHWEST FIREPROOFING PRODUCTS CO — Types 4, 5, 5EF, 5GP, 5MD, 7GP, 7HD, 8EF, 8GP, 8MD, 9EF, 9GP, 9MD, DK, DK2, DK3.

GCP APPLIED TECHNOLOGIES INC — Types MK-6/HY, MK-6s, RG, SK-III, Monokote Acoustic 1.

8. **Steel Studs with Discs** — The stud consists of No. 12 SWG steel wire, of a length 3/8 in. shorter than the thickness of protection material, with one end welded to 1-3/16 in. diam, No. 28 MSG galv disc. The total number of studs shall avg at least one stud per 236 sq in. of cellular floor units beneath the trench header. The studs shall be welded to the cellular floor units with discs down and in rows running parallel with the trench header. The distance between the rows and the edge of the trench header shall not exceed 4 in. The spacing between the rows shall not exceed 22 in. The spacing between studs along the rows shall not exceed 24 in.

9. **Metal Lath** — (Not Shown) — Where Type 7HD is applied to steel deck, 3/8 in. metal ribbed lath weighing 3.4 lb/yd² shall be secured to the underside of the steel deck (ribs upward) with S-12 by 3/8 in. long pan head, self-tapping steel screws spaced 12 in. OC in all directions. Steel screws shall be fitted with 1/2 in. diameter steel washers. Adjacent pieces of lath shall be overlapped 1 in. min.

*** Indicates such products shall bear the UL or cUL Certification Mark for jurisdictions employing the UL or cUL Certification (such as Canada), respectively.**

Last Updated on 2021-05-11

The appearance of a company's name or product in this database does not in itself assure that products so identified have been manufactured under UL's Follow-Up Service. Only those products bearing the UL Mark should be considered to be Certified and covered under UL's Follow-Up Service. Always look for the Mark on the product.

UL permits the reproduction of the material contained in the Online Certification Directory subject to the following conditions: 1. The Guide Information, Assemblies, Constructions, Designs, Systems, and/or Certifications (files) must be presented in their entirety and in a non-misleading manner, without any manipulation of the data (or drawings). 2. The statement "Reprinted from the Online Certifications Directory with permission from UL" must appear adjacent to the extracted material. In addition, the reprinted material must include a copyright notice in the following format: "© 2021 UL LLC"